

FOR 380V-440V-460V-480V SUPPLY VOLTAGE  
MOVE THE GREY WIRE

W = WHITE  
R = RED  
P = PINK  
B = BLUE  
Y = YELLOW

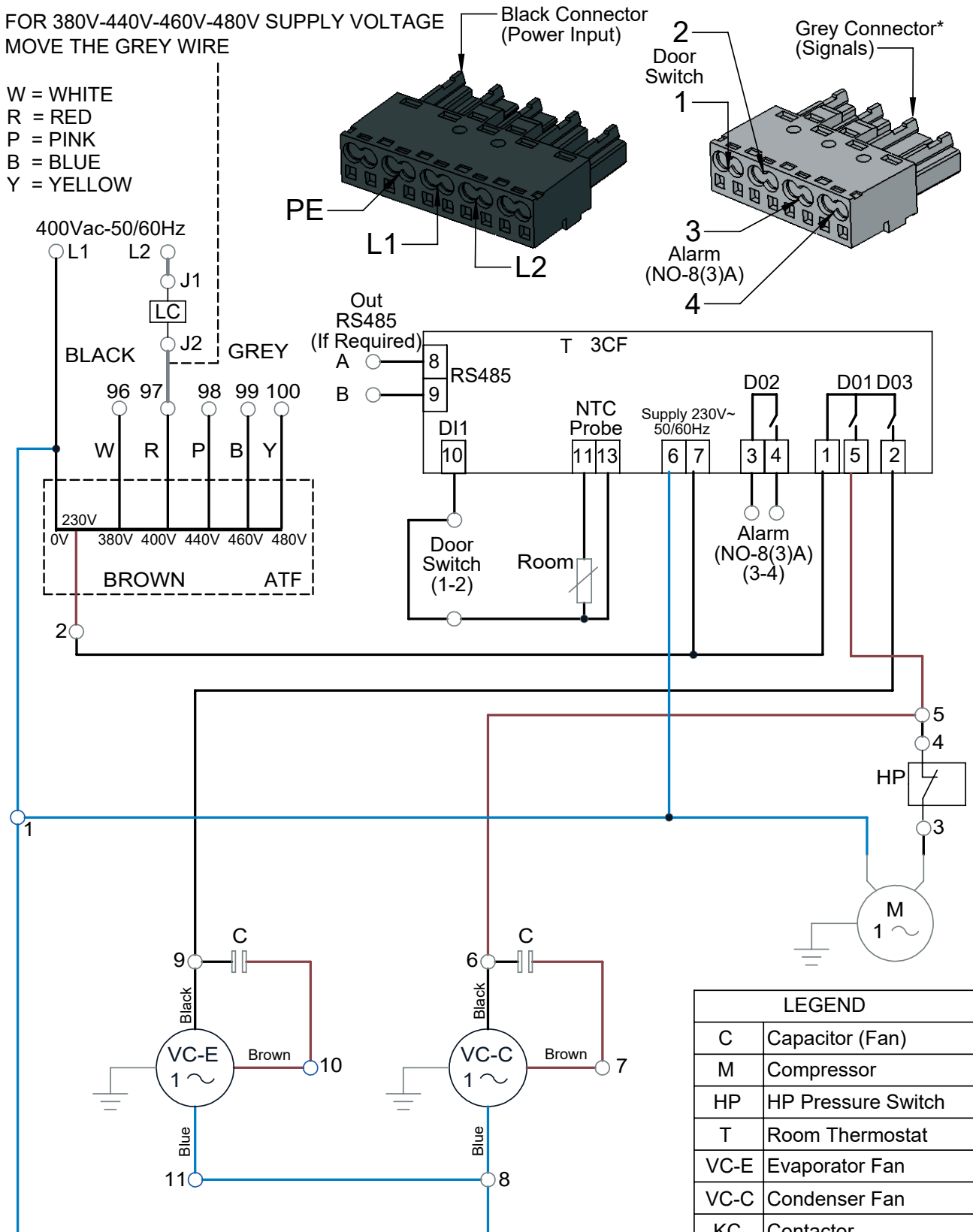

\*Even if the alarm output or door contact is not used, the grey plug with the bridged door contact loop (red bridge) must be inserted, otherwise the cooling unit will not start.

LEGEND	
C	Capacitor (Fan)
M	Compressor
HP	HP Pressure Switch
T	Room Thermostat
VC-E	Evaporator Fan
VC-C	Condenser Fan
KC	Contactore
ATF	Autotransformer
LC	Current Limiter Inrush